

**CRYPTAG<sup>®</sup>**

**READER MANUAL**

**IDENTEC READER TYPES RC2, RC4, RW2 and RW4**

IDENTEC LIMITED  
Mercantile Road  
Rainton Bridge Industrial Estate  
Houghton-le-Spring  
Co. Durham. DH4 5PH

Tel: +44 (0) 191 584 4084  
Fax: +44 (0) 191 584 9077  
Technical support: 0800 018 1661  
Web site: [www.identec.co.uk](http://www.identec.co.uk)  
e-mail: [info@identec.co.uk](mailto:info@identec.co.uk)

Last revised October 2000

This manual is provided for information purposes only. All information included in this manual is subject to change without notice. Identec is not responsible for any damages, direct or indirect, arising from or related to the use of this manual, or associated product.

© Copyright 2000 Identec Limited. All rights reserved.

Printed in the United Kingdom.

This manual may be reproduced by Identec's customers for the purpose of assisting with the installation of Cryptag equipment. Reproduction in any form, physical or electronic, of all or part of this manual for any other purpose requires the express written permission of Identec Ltd.

**Trademark Notice:**

Cryptag is a registered trademark of Identec Ltd.  
Identec is a registered trademark of Identec Ltd.

**Patents:**

Patents in the UK and other countries protect Cryptag systems.

*WARNING NOTICE*

This product uses radio frequency signals, and is therefore subject to possible interference. Any application should bear this in mind, and in particular it should not be possible for personal safety to be jeopardised by a failure to read.

This reader neither uses nor generates hazardous voltages. You should not connect any such voltage to it.



This product complies with the following European Community directives

**Low Voltage Directive.** (73/23/EEC)  
**EMC Directive.** (89/336/EEC)

## **FCC Regulations**

This device complies with Part 15 of the FCC Rules. Operation is subject to the following two conditions:

- (1) this device must not cause harmful interference, and
- (2) this device must accept any interference received, including interference that may cause undesired operation.

FCC GRANT AUTHORISATION: JHD-CPW

# CONTENTS

		<b>Page</b>
<b>Chapter 1</b>	<b>Cryptag Readers RC2, RC4,RW2 and RW4</b>	3
1.1	Introduction	3
1.2	Unpacking	3
1.3	Getting Started	3
<b>Chapter 2</b>	<b>Reader Location</b>	4
<b>Chapter 3</b>	<b>Installation and Commissioning</b>	6
3.1	Preparation	6
3.2	Connections	6
3.3	Mounting	6
3.4	Commissioning	7
3.5	Warning Labels	8
<b>Chapter 4</b>	<b>Trouble-shooting</b>	9
<b>Chapter 5</b>	<b>Technical</b>	11
5.1	Principles of operation	11
5.2	Reading Range	11
5.3	Dimensions	12
5.4	Environmental	12
5.5	Electrical	12
5.6	Cryptags	14
<b>Figures</b>		
Figure 1	Reader Block Diagram	15
Figure 2	Interfaces	16
Figure 3	PCB Connections, Master and Slave.	17
Figure 4	Master layout	18
Figure 5	Slave layout	19
<b>Appendix A</b>	<b>Output Formats and Data Connections</b>	20
<b>Appendix B</b>	<b>Power Supplies and Earthing</b>	22
<b>Appendix C</b>	<b>RC4 Look-up Table</b>	25

# 1. CRYPTAG READERS RC2, RC4, RW2 and RW4

## 1.1 Introduction

Cryptag is a radio frequency tag identification system. Its multiple reading feature means that the reader can simultaneously identify and report one or more tags.

This combined manual covers the following reader types

RC2 Wiegand Output	RC2 RS232 Output	RC2 Clock/Data Output
RC4 Wiegand Output	RC4 RS232 Output	RC4 Clock/Data Output
RW2 Wiegand Output	RW2 RS232 Output	RW2 Clock/Data Output
RW4 Wiegand Output	RW4 RS232 Output	RW4 Clock/Data Output

RC2/RC4 and RW2/RW4 are double readers, each made up of a Master (Reader) unit and an additional Slave Aerial unit. The double reader gives a higher level of tag detection.

RC4 readers contain an internal look-up table which modifies the way in which the tag's identity is reported, whereas RC2 readers report a number which is derived directly from the tag's identity. See Appendix A for details of output formats.

RW2 and RW4 readers are similar to RC2 and RC4, but are supplied in wooden housings. They are used when the reader cannot be seen.

**As RW2/RW4 are in almost all cases the same as RC2/RC4, this manual will refer only to RC2 and RC4 except where there is a difference.**

## 1.2 Unpacking

Check that the package contains

- Reader (2 units and a pre-wired interconnecting cable)
- 16 screws and plastic caps (RC2/RC4 only)
- Warning label
- Manual

## 1.3 Getting started

*(If you are new to Cryptag readers, just follow these simple instructions.)*

1. Connect a 12V power supply to the Master (reader) unit.  
The positive connection (cyan, white and pink wires) goes to 12V on the main terminal block (see Figure 3) and the negative connection (purple, grey and yellow wires) goes to 0V.
2. Position the two units that make up the reader about 1.5 metres (5 ft) apart and facing each other. See diagram on the next page. Bring a tag between and outside the two units of the reader.  
The reading range should be 1.5 metres (5 ft) for a TM1 tag. Note how the range depends on the tag's orientation but between the two units the effect of orientation is reduced.
3. LED3 on the reader will flash regularly when a tag is being read. (LED3 is only visible when the cover is removed.)  
When no tag is present LED3 may flicker if noise is present. Learn to recognise the difference when a tag is being read.
4. The reader reports a tag only once.  
Although a tag is being read continuously, the reader will report it only once. To get another report the tag has to be removed completely first.

## 2. READER LOCATION

- 2.1 The reading range of the RC2/RC4 is such that some care is needed in selecting the reader's location.

Do not locate a Cryptag reader too close to another reader

If tags can pick up signals from two or more readers they respond to neither. The minimum separation is  $1\frac{1}{4}$  times the combined reading range (i.e.  $2\frac{1}{2}$  times the range of two similar readers).

Do not mount the reader directly on to metal

This will reduce reading range and increase current consumption.  
Do not place readers within 300mm (1 ft) of metal structures.

Keep the reader away from possible interference sources

Interference (also referred to as noise) can reduce the reading range and make reading slower. Computer monitors can affect performance at up to 5m (16ft). Most monitors have less effect, but it does depend on the scan frequency.

A Site Survey (using an MS1 Site Survey Meter) is desirable.

The RC2/RC4 Master/Slave unit is used to provide a high probability of detection **for tags which pass between the two units** that make up the reader. The two units that make up the reader should be positioned facing each other on either side of the corridor that is to be covered. The separation should not exceed 2.0 metres ( $6\frac{1}{2}$  ft), although for best results 1.5 metres (5 ft) or less is preferred. Remember that tags will be read within a radius of 1.5 metres (or more) from either unit.

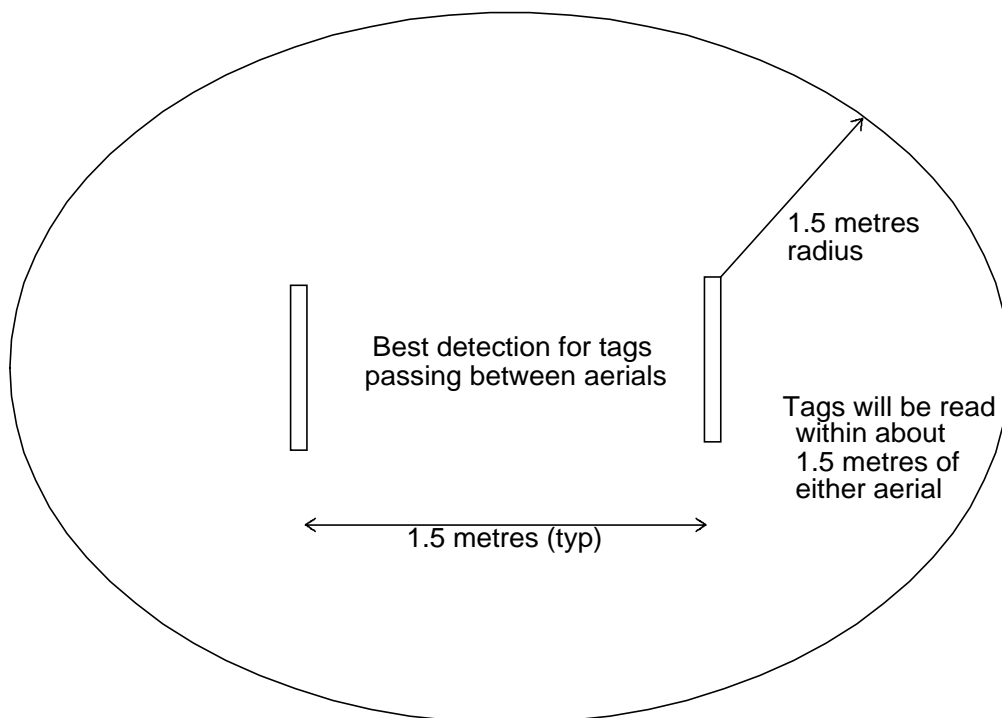

## 2.2 *Screening*

If two RC2/RC4 readers are to cover parallel corridors it is possible to screen them from each other using a ferrous metal sheet (e.g. mild steel 1mm thick). The screen must be larger than the aerials (minimum 1.4 metres by 0.9 metres) and must overlap the aerials by at least 0.2m on each side.

The aerials should be at least 8cm from the screen, and must be parallel to the screen. Below 15cm separation there is some reduction in range, which may limit the width of the corridor that can be covered.

During commissioning, it will have to be noted that a tag will not respond when it is within range of both readers. Performance may be improved by turning down the transmitter power of the aerials on either side of the screen.

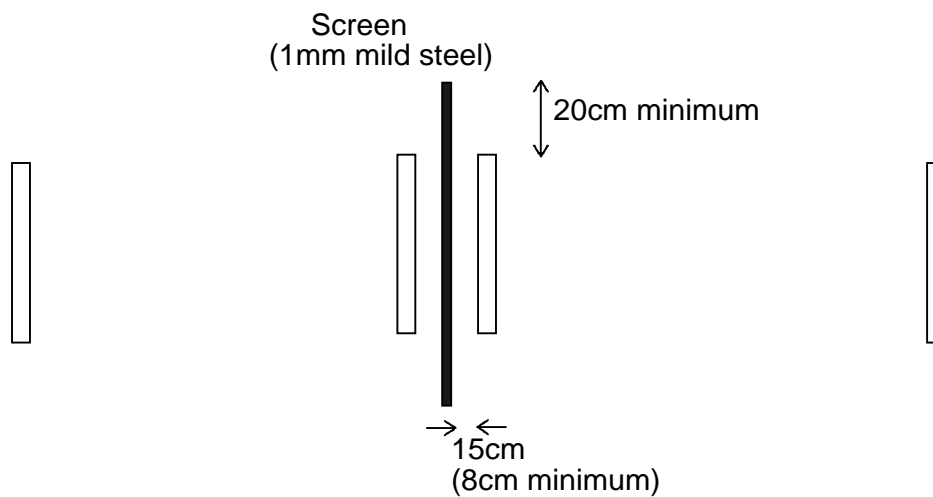

### 3. INSTALLATION AND COMMISSIONING

#### 3.1. Preparation

Open the Master Unit by removing the front screws.  
Loosen the terminal blocks.

#### CAUTION

**Take care not to move or damage internal components**

It should not be necessary to open the Slave Aerial unit at present.

#### 3.2 Connections

For most installations using Wiegand format, the connections will be

0V	Power supply –ve (and data reference)
12V	Power supply +ve (12V to 14V, 450mA typical)
D0	Wiegand D0 line
D1	Wiegand D1 line
LED	LED control (high or floating for red, low for green) (No LED on RW2/RW4)

The HOLD line can be used to buffer the output data, if there is a suitable signal available.

For details of other output formats refer to Appendix A. This includes the relay connections which are only provided on RS232 output readers.

The reader has the option of an isolated output section. For details of how to use this refer to Appendix B.

Readers are supplied with 5 metres (16 ft) of 12 core screened cable.

0V	Purple, Grey and Yellow (3 wires in parallel)
+12V	Cyan, White and Pink (3 wires in parallel)
D0	Black
D1	Brown
LED	Blue
0V(W)	Green
+5V(W)	Red
HOLD	Orange

The power connections (0V and +12V) have three wires in parallel to minimise the voltage drop in these lines. The power supply voltage **at the either part of the reader** should be a minimum of 12V.

#### 3.3 Mounting

3.3.1 Select a convenient position for the Master and slave units.

3.3.2 The units should be mounted using the fixing holes provided. Do not drill into either part of the reader, as this might cause damage.

- 3.3.3 Run the cable, avoiding excessive tension on the cable, and make the required connections. If the cable needs to be extended, check that the voltage drop on the power lines will not be excessive. (Assume a current of 600mA.)

If it is necessary to disconnect the umbilical cable between the two parts of the reader, make sure that the connections are replaced correctly.

- 3.3.4 If the Reader is not to be commissioned immediately replace the cover on the Reader.

### 3.4 **Commissioning**

*If any problems are experienced during commissioning, refer to the Trouble-shooting Section (Section 4)*

- 3.4.1 If necessary remove both covers. Check the following-

**Wiring** is correct and secure

**Links** are correctly positioned

If there is no wire to 5V(W) then LK1 and LK2 should be in. There need be no wire to 0V(W), which is connected to 0V.

If there is a wire to 5V(W) but no wire to 0V(W) then LK1 should be in and LK2 should be out.

If there are wires to 5V(W) and 0V(W) then both links should be out.

**Potentiometers** are fully clockwise on both Master and Slave.

A range of suitable **Cryptags** is available.

For **RC4** readers, ensure that the **look-up table** has been loaded. (Appendix C.)

- 3.4.2 Apply power to the system. On RC2/RC4 readers the red indicator LED (LED1) should come on. Green (on LED2) means that the LED input is being pulled low. RW2/RW4 readers do not have LED1 and LED2. When power is first applied LED3 comes on momentarily.

Measure the voltage between 0V and +12V terminals of the Master unit. This voltage must be at least 12V, and it must not exceed 14V. On the Slave unit, check that the voltage on +12V and +12R are both at least 12V.

- 3.4.3 Ensure that there are no Cryptags close to the Reader

If the internal LED (LED3 on the Master) is on at all, turn RV1 on the Master anticlockwise until LED 3 is permanently off. (If there are no Cryptags present LED 3 will only light if there is external interference. Reducing receiver sensitivity using RV1 will eliminate interference, but it may also affect the range and may impair the reader's ability to achieve a high detection rate.)

- 3.4.4 Turn R8 on the slave unit fully anticlockwise. Bring a Cryptag towards the Master Unit to measure the range of the Master Unit, which is shown when LED3 is flashing. The best place to measure is behind the Master Unit (well away from the Slave Aerial) but this isn't always practical. With the Slave turned right down, a tag positioned face on to the reader should be read right across the corridor. (The minimum is 75% of the corridor width.)

- 3.4.5 If the range of the Master Unit is greater than desired, reduce the transmitter power output using RV2 until the desired range is achieved.

3.4.6 Note the setting of RV2, then turn RV2 right down (anti-clockwise). Turn R8 on the Slave Aerial fully clockwise, then use the same procedure to adjust R8 on the Slave to give the required range.

Note:

It is possible to set the Master and Slave units to give different ranges, but the detection rate will not be as good.

- 3.4.7 RV1 (threshold, on the Master unit) should be re-adjusted for best performance, setting the threshold level so that noise is ignored, but tags are read. Turn RV1 fully clockwise, and then turn it slowly anti-clockwise until LED3 stops flickering. A small amount of flickering is acceptable, but a large amount of flickering will make reading slow.

It is possible that one part (either Master or Slave) is subject to more noise than the other. This is bad because the noisier receiver dominates. Ideally the noise should be eliminated, but if this is not possible the noisy receiver should have its sensitivity reduced. Solder a resistor across the output terminals of the tuning board next to the ferrite rod. The resistor value should be between 22k (which has only a small effect) down to 1k (after which the performance is likely to be totally unacceptable).

- 3.4.8 Now check that tags will be read everywhere (and in most orientations) between the two parts of the reader. Check that tags will not be read in adjacent rooms and on the next floor up or down.

Get people to carry tags through the reader, noting where tags are detected. Have them carry the tags in different ways (e.g. lapel, necklace, on a belt).

- 3.4.9 Now carry out system checks with the equipment to which the Reader is connected. (In the Fault Finding this is referred to as the controller)

- 3.4.10 Replace the covers and fit the screws. On RC2/RC4 fit the plastic caps.

### 3.5 *Warning Labels*

Each Reader is supplied with a Warning Label which identifies a Cryptag Control Zone and advises against loitering. These labels are particularly recommended for situations where Active Cryptags might be left in the vicinity of a reader.

## 4. TROUBLE-SHOOTING

The equipment to which the reader is connected is referred to here as the controller. The controller is expected to receive the output signal (Wiegand, RS232 or Clock/Data as applicable). It should also control the external LEDs.

The external LED indicators will either indicate red or green. If one goes out the other should come on. It may be possible for them both to appear to be lit, if an a.c. waveform is transmitted.

### 4.1 **For RC2/RC4 readers, no indicating LED on ( both LED1 and LED2 off when power applied)**

Check: +5V(W) with respect to 0(W).

If 5V is not present - Check wiring and links LK1, LK2

If 5V is present - Replace Reader

### 4.2. **LED3 does not come on when Cryptag presented**

Check: +12V with respect to 0V (not 0V(W)).

If 12V is not present - Check wiring to Reader

If 12V is present - Either Cryptag or Reader is faulty

Check: Adjustment of RV1 and RV2 (See Commissioning section.)

### 4.3 **LED3 permanently flickering**

Re-adjust RV1 (See Commissioning Section)

If LED3 is beating steadily, look for a tag within range of the reader.

### 4.4 **LED3 responds to tag but no response by Controller**

Check: Cryptags are valid for this Reader (refer to Appendix A for RC2 and Appendix C for RC4.)

Check: Wiring to Reader and correct if necessary.

Check: Is Hold line high. If it is low (<2.5V) the Reader will not transmit data .

**NOTE:** The presence of pulses could be tested with a Logic Probe or oscilloscope.

### 4.5 **Indicating Red/Green LEDs not operating (always in the same state – RC2/RC4 only)**

Check: Voltage on LED input

If voltage is +5V - red LED should be on

If voltage is 0V - Green LED should be on.

The operation of the LEDs can be checked by removing the connection to the LED input. The red LED should be on. Now short the LED input to 0V(W). The green LED should come on (and the red LED go off).

#### 4.6 **Range insufficient / Insufficient Coverage**

Check: Is either aerial mounted on metal? (See Section 2.2)

If so then range can be improved by lifting the aerial off the metal

Try connecting GND to the metal.

Check: Are there any closed metal loops near either aerial?

Check: Is the reader close to a computer monitor or any other potential source of interference?

Check: Is either aerial too close to another Cryptag reader?

Check: Adjustment of RV1 and RV2 on the Master and R8 on the Slave (See Commissioning Section)

Check: Tag orientation is correct (including rotation in its own plane). This should only apply when checking an individual aerial.

#### 4.7 **Unreliable or Slow Reading**

Check: Adjustment of RV1 (See Commissioning Section)

Try connecting GND to metal.

See also the checks for insufficient range.

## 5. TECHNICAL

### 5.1 *Principles of operation*

The reader consists of two aerial units which are referred to as the Master and the Slave. Each aerial contains a transmitter and a receiver, which are both under the control of a processor in the Master.

The transmitters send out signals that will be picked up by any Cryptag in their vicinity. The transmitters produce a combined field, and a tag will respond if it can detect a signal from either transmitter. The outputs of the receivers are combined electronically so if either can detect a tag then that tag will be seen by the reader and a dialogue takes place which identifies the Cryptag. The nature of the dialogue is well disciplined so that more than one Cryptag can be interrogated and correctly read without interaction.

After the interrogation dialogue the Reader communicates the identity of valid tags it has seen. Tag transmissions are buffered.

### 5.2 *Reading Range*

For each aerial the reading range with an active Cryptag (TM1) is 1.5 metres (5 ft). Range quoted is typical under optimum conditions and with a minimum 12V supply. Normal variation is  $\pm 10\%$ .

The range at which a Cryptag will be identified is affected by -

Cryptag orientation - Figures quoted assume optimum orientation. Rotating through  $45^\circ$  reduces the range by about 15%. At exactly  $90^\circ$  tags will not be read at all. The optimum orientation varies around the reader. The Master/Slave arrangement greatly reduces the effect of different orientations, as a tag will be read unless its orientation is wrong for both the Master and the Slave.

Presence of metal - The Aerials should not be mounted directly on or near a metal surface. As well as reducing range metal will increase power consumption. (But see Section 2.2.)

Electrical interference - The transmission from Cryptag to Reader is at low power and may be affected by sources of electrical interference such as computer monitors.

The range of the aerials can be deliberately reduced. There is a potentiometer on each aerial to reduce the power of transmissions to the tag and therefore reduce range. Another potentiometer reduces the overall input sensitivity of both receivers. This eliminates interference, and in some cases reducing the sensitivity may increase the range.

### 5.3 *Dimensions (each aerial)*

	RC2/RC4	RW2/RW4
Height	1005mm (39.6 inches)	1000mm (39.4 inches)
Width	505mm (19.9 inches)	500mm (19.7 inches)
Depth	42mm (1.65 inches)	38mm (1.5 inches)
Weight	10kg (22lb)	8kg (18lb)

(The total weight of an RC2 is thus 20kg (44lb).)

### 5.4 *Environmental*

Temperature	-20 <sup>0</sup> to + 60 <sup>0</sup> C (-4 <sup>0</sup> F to 140 <sup>0</sup> F)
Housing Material	RC2/RC4 - Glass filled plastic RW2/RW4 - Wood
Mounting	Normally vertical. RC2/RC4 is suitable for indoor or outdoor use. RW2/RW4 is only suitable for indoor use.

### 5.5 *Electrical*

5.5.1 Power Input

12V minimum to 14V maximum  
450mA typical, 550mA maximum including 15mA interface circuit current.  
(Current measured at nominal supply voltage, maximum transmitter power, no tags present and with the reader on a non-metallic surface.)  
If both aerials are mounted 1cm from a metal surface, the current consumption can rise to 750mA maximum.

#### 5.5.2 Outputs (see Figure 2 for interface circuits)

Data Output	DATA0 and DATA1 lines. Normally high (+5V), pulsing to low 0.4V. Format - See Appendix A. 1k ohms pull-up to 5V(W). In Wiegand and Clock/Data readers the data lines <b>cannot handle more than 5mA maximum.</b>
LED	Input impedance 100k ohms pull-up to + 5V(W) High or floating for RED Low for GREEN Nominal switching level 2.5V.

HOLD	<p>Input impedance 100k ohms pull-up to 5V(W)  Input capacitance 1nF  High or floating for Data output  Low to freeze data output transmission  Nominal switching level 2.5V</p> <p>(NOTE. If HOLD goes low during a transmission, that transmission will continue to completion.)</p>
Data Buffer	Up to 10 tags can be stored. This limits the number of tags that can be identified simultaneously.
Max Voltage	<p>The + 5V(W) input must never exceed 6.5V  Other data lines (DATA0, DATA1, LED, HOLD) must not fall below - 0.3V or above 6.5V.</p> <p>Protection circuits are incorporated to prevent damage from transient spikes (above normal EMC limits).</p>
Cable Length (Data)	<p>Wiegand and Clock/Data - 100m (300 ft) maximum.  (NOTE. Cable length may also be limited by the equipment at the other end.)</p> <p>RS232 - 20m (60 ft) maximum (9600 baud)</p> <p>Power supply cable length is limited by voltage drops.</p>
Output Timing	<p>When the Cryptag has been read its identity is stored. The identity data is buffered to ensure that there is a minimum inter-burst period between a pair of data transmissions. The inter-burst time is configurable, and the standard value is 100ms.  (See Appendix A).</p>
Interrogation Time	230ms maximum per Cryptag. This may increase in the presence of interfering signals.
Transmission Time	Nominally 1ms per bit, but can be altered on request. (See Appendix A.)
Pulse Width	Nominally 50 $\mu$ s.

### 5.5.3. Radio Transmissions

Reader to tag	<p>132kHz carrier  Magnetic field, &lt;58.5db <math>\mu</math>A/m at 10m</p>
Tag to reader	<p>66kHz (Phase locked to 132kHz)  Magnetic field, &lt;-10db <math>\mu</math>A/m at 10m.</p>

#### 5.5.4 EMC

Emission	Exempt according to MPT1337 (Dept of Trade and Industry)
Susceptibility	Not affected by 4kV, 150ns pulses (such as defined by IEC Standard 801-4, 1988)

#### 5.6 *Cryptags*

Current Cryptag types are:

- TM1 personnel tag
- TA1 article tag
- TK3 keyfob tag (replaceable battery)

All of these are active (battery powered) tags.

All Cryptags have a Public Identity (PID) of 16 bits and a Hidden Identity (HID) which is theoretically 16 bits, but in practice one bit cannot be identified and the useful size is 15 bits. The identity of the Cryptag is a total of 31 bits giving 2 billion possible identities.

Current production tags are programmed by Identec and can be supplied with sequential numbers. Once the identity has been programmed it cannot be altered, and tag identities are not duplicated.

Older (pre 1999) tags had a fixed identity. In order to obtain sequential numbering with older tags it is necessary to use an RC4 reader with its look-up table, as described in Appendix C.



Wiegand outputs (also Clock/Data, but not RS232)

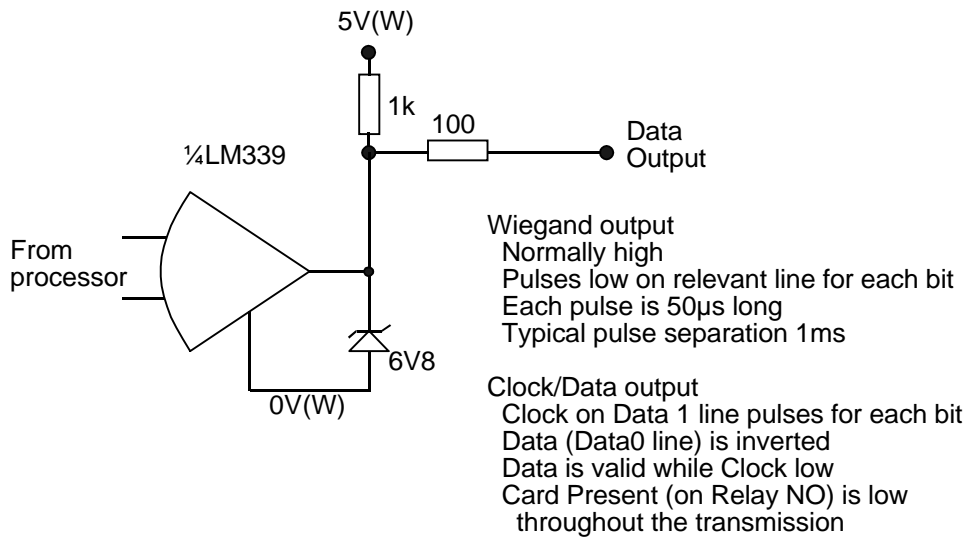

LED and Hold inputs

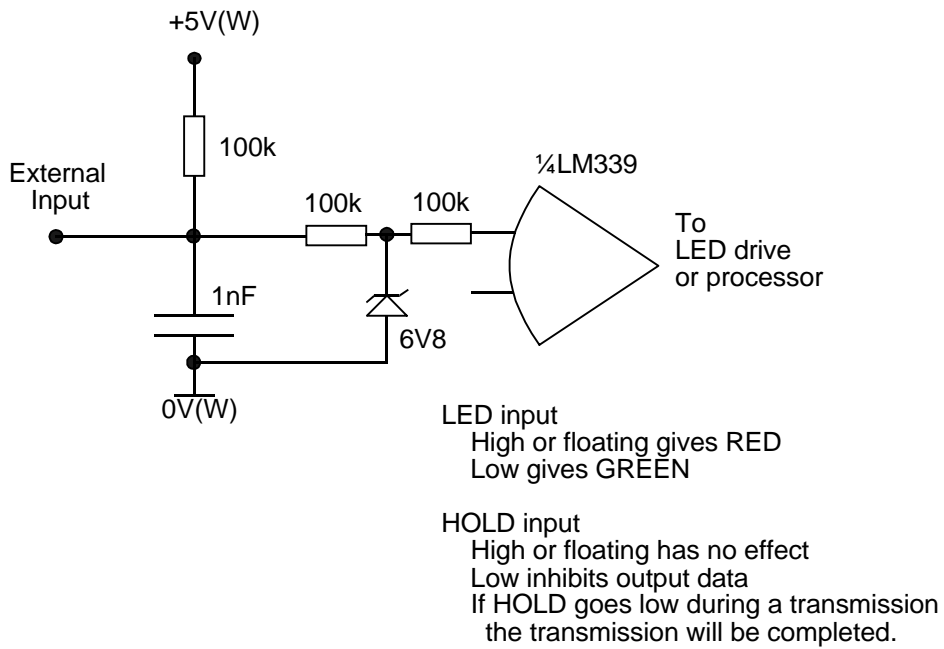

Fig 2: Interfaces

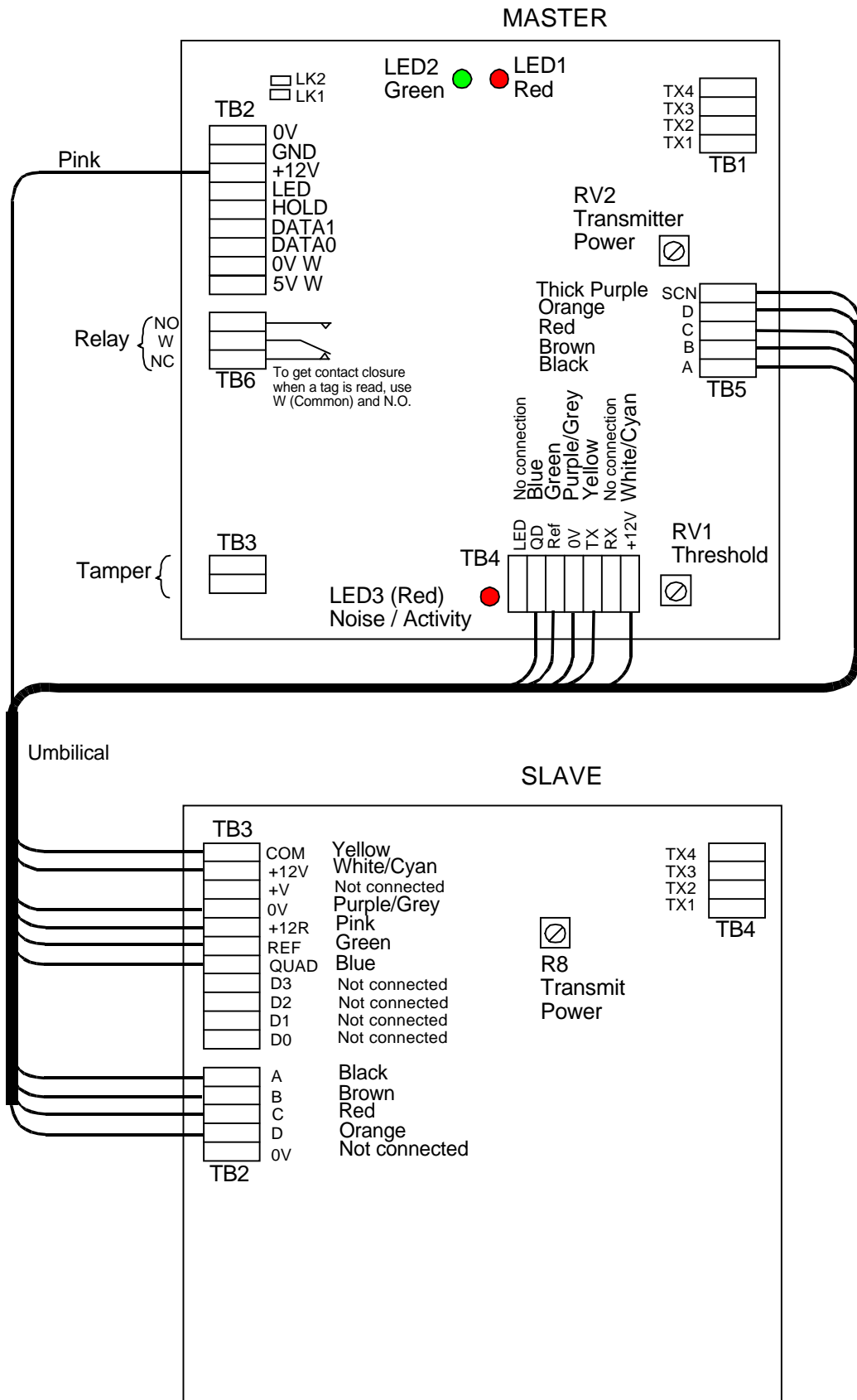

Figure 3: Master and Slave Unit connections

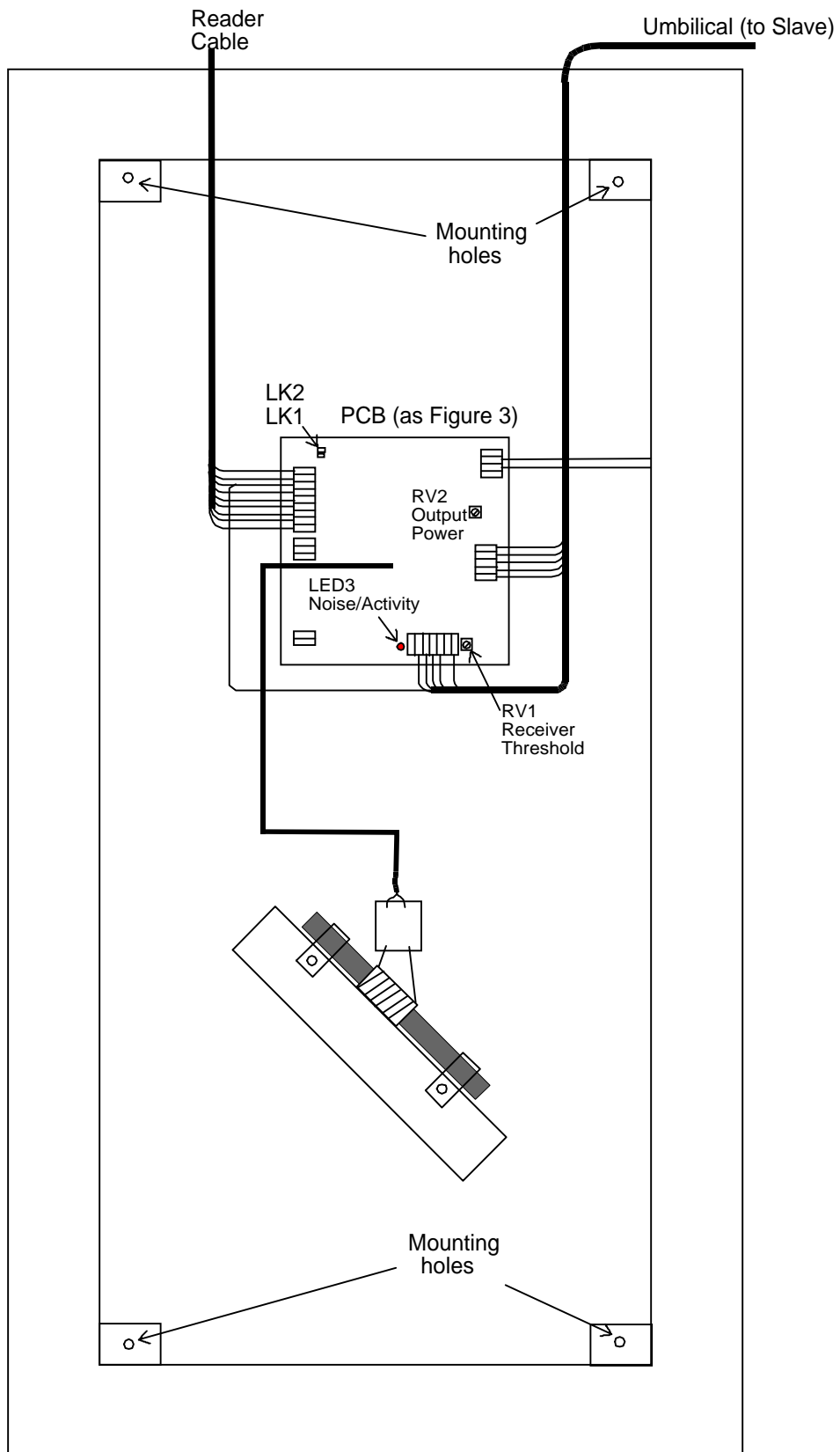

Fig 4: Master Aerial Layout

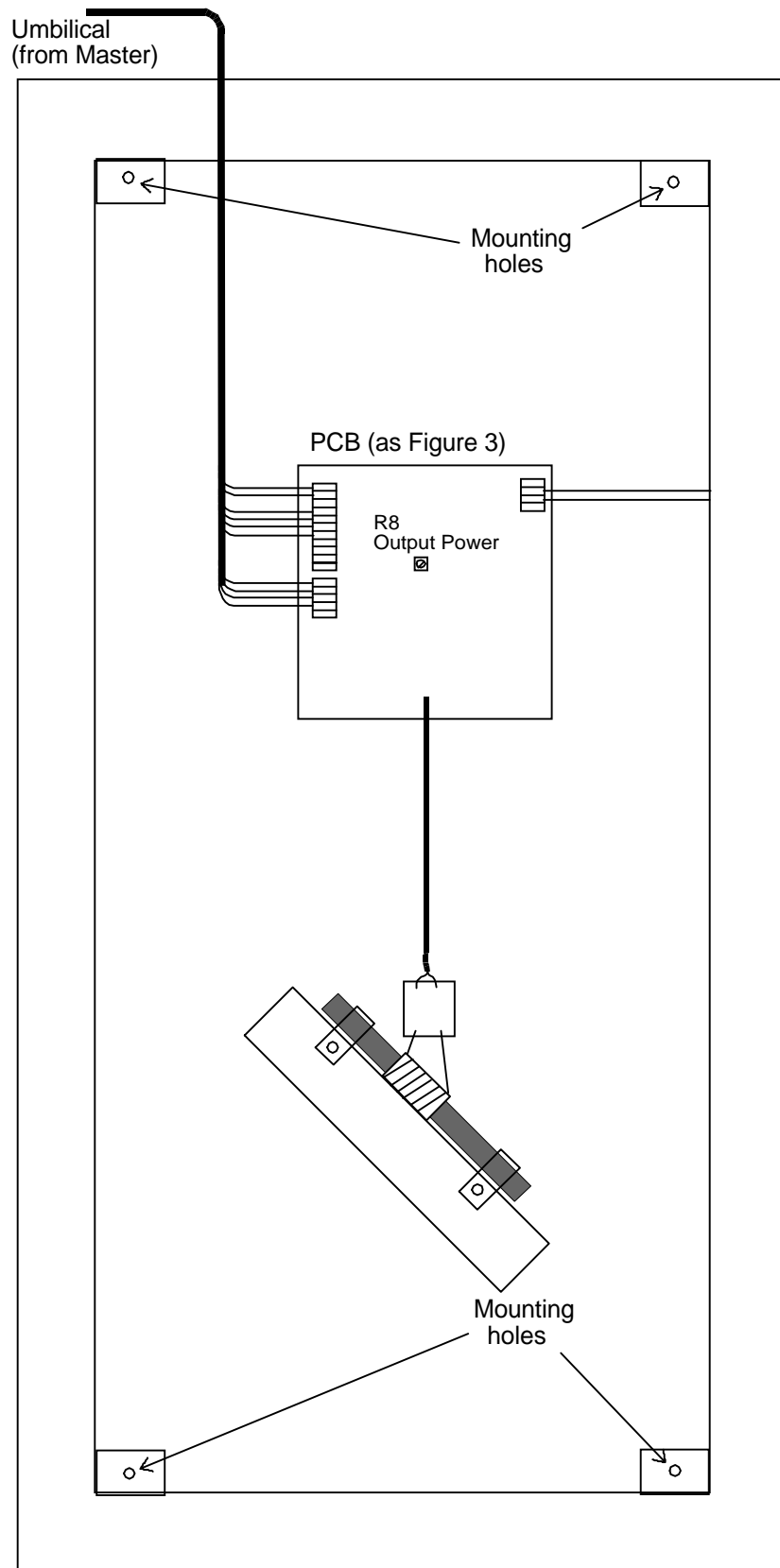

Fig 5: Slave Aerial Layout

## APPENDIX A

### Output Formats and Data connections

The output format of the reader is configurable. This appendix gives some typical formats and the terminal connections to use.

#### A.1 Wiegand output

The number of bits and their allocation is usually customer specific, but some RC2 readers are supplied with a standard 26 bit format.

Output bit	
1	Even parity on Bits 1-13
2-9	Hidden Identity (least significant byte)
10-25	Public Identity
26	Odd parity on Bits 14-26

The most significant part of the Hidden Identity (HID) is ignored. (On some RC2 readers, it will be checked so only tags with some HIDs will be reported.) Tags are reported when they are first seen, and then only if the tag has been out of the field for at least 2 seconds.

Timing      1 ms bit period  
              50µs bit low pulse for each bit

Buffering    The reader ensures a minimum period (100ms) between transmissions. This ensures that the controller does not confuse the two transmissions.

With current Cryptags the tag numbers are programmed to suit customer requirements. If older tags (pre 1999) are present on the site there is a possibility of numbering problems if the Access Control system is not sufficiently flexible. Two ways to avoid these are

- a) Use RC4 readers, as described in Appendix C.
- b) Make the user number as long as possible (ideally 31bits) and derive the tag number from the tag's identity

$$\text{Tag number} = \text{HID} * 65536 + \text{PID}$$

#### A.2 RS232 output

The standard output format is 9600 baud, 8 data bits, no parity and one stop bit. The data transmitted is

HID:HHHH PID:PPPPP<LF><CR>

Where HHHH is the Hidden Identity in hexadecimal, and P P P P P is the Public Identity in decimal, <LF> is line feed and <CR> is carriage return.

The RS232 output is on the D0 terminal. The D1 terminal is not used. RS232 readers have a single pole relay fitted, as shown in Figure 3. The HOLD input has no effect on RS232 readers.

### A.3 *Clock/Data output*

This format emulates magnetic stripe card readers, and is supplied to conform to specific customer requirements. For details of the encoding format, contact Identec.

Terminals for Clock/Data output readers

D0	Data output (inverted data)
D1	Clock output (Data output is valid while Clock is low)
Relay NC	Card Present (low throughout data transmission)

## APPENDIX B

### Power Supplies and Earthing

*This Appendix explains the options available, when they should be used, and how to implement them.*

#### B.1 Circuitry

Refer to Figure 1 (Block Diagram).

The reader has two sets of Circuitry, which are electrically isolated using opto-isolators.

Reader Electronics -	Connected to 0V +12V
Output Interface -	Connected to 0V(W) +5V(W)

The ground connection (GND) is connected via 1nF capacitors to 0V and +12V.

The other connections (DATA 0, DATA 1, LED, and HOLD) are connected to the Interface Circuitry, and must be referenced to 0V(W)

The Reader electronics contain a 5V regulator. This can also be used to supply the Interface Circuitry

There are two links related to the power supplies -

- LK1 connects 0V and 0V(W)
- LK2 connects 5V(W) to the Reader's own 5V

#### B.2 Normal Arrangement (Interface powered internally)

In this arrangement the external connections are -

0V	LK1 In
+12V	LK2 In
DATA 0	
DATA 1	
LED	
HOLD	

0V and 0V(W) are connected by LK1  
5V and 5V(W) are connected by LK2

All outputs are referenced to 0V (and to 0V(W) ).

This arrangement will be used when the Controller (the unit to which the Reader is connected) can provide a 12V supply with sufficient current.

The 12V supply must be capable of supplying 500mA. If the Reader is mounted on metal the current can rise to 600mA. The current requirement is reduced if the range is reduced using RV2.

### B.3. *Separate 12V supply (non-isolated, with interface powered externally)*

This arrangement is used when the controller cannot provide the required 12V power and an external supply is used. The 12V supply must not be grounded except through the Reader.

Connections are -

0V	LK1 In
+12V	LK2 Out
+5V (W)	
DATA 0	
DATA 1	
LED	
HOLD	

0V and 0V(W) are connected by LK1. It is best to use the 0V connection. 5V(W) is supplied separately by the controller so LK2 is out.

The outputs are referenced to 0V (and to 0V(W) ).

The 12V supply must be capable of supplying 485mA. If the Reader is mounted on metal the current can rise to 585mA. The current requirement is reduced if the range is reduced using RV2.

The 5V Interface Circuitry supply current (taken from the controller) will be 15mA.

### B.4 *Totally Isolated*

This arrangement is used when the Reader and/or its 12V supply must be totally isolated from the interface to the controller. A typical case will be when the 12V supply is shared, and the other use must itself ground the 0V line.

Connections are -

0V	LK1 Out
+12V	LK2 Out
0V(W)	
+5V(W)	
DATA 0	
DATA 1	
LED	
HOLD	

Interface circuitry connections are referenced to 0V(W) and not 0V.

The 12V supply must be capable of supply 485mA. If the Reader is mounted on metal the current can rise to 585mA. The current requirement is reduced if the range is reduced using RV2.

The 5V Interface Circuitry supply current will be 15mA max.

### ***B.5. Ground***

The GND connection can be connected to local metal objects. This may improve range if the Reader is affected by some types of interference.

## APPENDIX C

### RC4 Look-up Table

*This section applies to RC4 readers only. RC2 readers report the tag's identity number.*

#### C.1 Introduction

Cryptags have a unique identity number. In current production Cryptags this is programmed into tags before they are shipped, but in earlier (pre 1999) Cryptags the number was put in at an earlier stage. This meant that it was not possible to supply tags with particular numbers. Many Access Control systems do not have the flexibility to handle what are effectively random numbers, and the RC4 reader was introduced to provide sufficient flexibility for those applications.

The RC4 reader contains a look-up table in non-volatile memory. This stores the identities of tags which are valid for that site, together with the number that is to be reported for that tag. The numbers are reported as a Site Code (fixed for the site) and a User Number which is normally sequential.

The look-up table can be programmed into the RC4 reader in two different ways.

1. using ENCODER STATION LE1
2. using MASTER TAG MT1

Normally readers are configured initially using an LE1 Encoder Station, and the MT1 is a portable "encoder" used for updating installed readers.

#### C.2 Operation of Encoder LE1 (for full instructions see LE1 Operational Manual)

The LE1 Encoder is used before a batch of tags and RC4 readers is shipped. The tags within the shipment are loaded into the encoder. Each tag is then given a small label which identifies its User Number.

The look-up table is downloaded into each of the readers for that shipment. Only readers that have the correct look-up table downloaded into them will report the tags correctly.

The look-up table can also be downloaded into an MT1 Master Tag. The look-up table can then be downloaded into existing readers on site.

#### C.3 Operation of Master Tag MT1

The MT1 Master Tag is most commonly used to upgrade an existing installation, for instance to add more tags. This will only work if the MT1 Master Tag is correctly programmed for that reader, so that a Master Tag is site specific. It is not necessary to remove the reader's cover before using the Master Tag..

## Master Tag Operations during upload

	Master Tag indications	
	RED	GREEN
Initially	OFF	OFF
Present in field, power up and data integrity test	ON	ON
Test Passed	OFF	ON for 5 seconds maximum If this state persists the Site Code is incorrect. Contact Identec.
Loading	OFF	Flashing (on & off equal times)
Load Finished	OFF	Flashing (on 3 times more than off) (Continued for 10 seconds after leaving field)
Red Led – Error message	RED	GREEN
Power up test failed	ON	OFF
Battery Low	ON	Flashing (on & off equal times)
Loading (Bad Frames)	ON OFF (Alternating)	OFF ON
Load Failed	FLASHING (on 3 times longer than off)	OFF

### Power Up Test Failed

Remove Master Tag from field and wait till no LEDs are on.  
Reintroduce to field

If it fails again try a different Reader. Failure again means:-

- a) Wrong Master Tag
- b) Fault in Master Tag
- c) Very low battery
- d) Reader transmit power set close to minimum

### Battery Low

OK for one reader upload but replace battery before next reader. Disconnecting the battery will not affect the stored data.

**Bad Frame**

This is OK but not recommended. Your master Tag will keep trying if it loads a bad frame. The more red light you see in general the harder it is finding it to upload so try a different position of the Master Tag relative to the Reader.

**Load failed**

Try again after removing the tag from the field.

Try a different Reader to see if the fault is in the Tag or the Reader

Report any difficulty to your supplier

*C.4 Example of Look Up Table.*

Tag number		User number
HID (Hexadecimal)	PID (Decimal)	(Decimal)
000D	00100	0001
0AAF	64436	0002
BDCE	37000	0003
000A	00010	0004
0A01	01952	0005
881F	26534	0006
6654	32212	0007
1010	11414	0008
		0009

Next Tag will be 0009